

S E R V I C E N O T E

SUPERSEDES: NONE

37717A PDH/SDH/Jitter Test Set**Serial Numbers:** 3345U00100 / 3345U99999**Options:** All**Internal Printer Problems****To be Performed by:** Qualified Service Personnel**Duplicate Service Notes:**

37714A-06 Serials: 3339U00100 / 3339U99999

37717B-06 Serials: 3509U00100 / GB00001171 (nominal)

Build Status: Below 1:12 (If Disc-Drive NOT fitted)

Build Status: Below 2:14 (If Disc-Drive fitted)

Situation

The reliability of the Internal Printer may be improved by carrying out some simple modifications.

This Service Note describes these modifications, and provides instructions for correct replacement of the paper-roll as this can cause printer problems if not done correctly.

Continued

DATE: April 1996

ADMINISTRATIVE INFORMATION

SERVICE NOTE CLASSIFICATION:

MODIFICATION RECOMMENDED

ACTION CATEGORY:	IMMEDIATELY ON SPECIFIED FAILURE AGREEABLE TIME	STANDARDS:	LABOR 0.5 Hours	
LOCATION CATEGORY:	CUSTOMER INSTALLABLE ON-SITE SERVICE CENTER	SERVICE INVENTORY:	RETURN SCRAP SEE TEXT	USED PARTS: RETURN SCRAP SEE TEXT
AVAILABILITY:	PRODUCT'S SUPPORT LIFE	AGILENT RESPONSIBLE UNTIL: April 1997		
AUTHOR: DBG	ENTITY: E610	ADDITIONAL INFORMATION:		

NOTE

To ensure long-term printer reliability, only ever use Agilent recommended paper. The correct part number is 9270-1299.

Solution/Action

Carry out the modifications described in the following pages using the listed parts.

These apply to all 37717A units.

Parts Required

Description	Part Number	Quantity
Paper Guide	37717-40010	1
Paper Tear Window	37721-40002	1
User-instruction Label	37717-00066	1
Paper Guide Screw	0515-0372	2
Window Tape	0460-1546	1 Roll

Internal Printer Description (All References are to Figure 1)

The Internal Thermal Printer is attached to a PCB behind Paper Tear Window (D). A replaceable paper roll (A) is located inside compartment (C). This paper roll fits onto spindle (F) attached to removable plastic cover (E). This plastic cover can be detached from the front panel (B) to allow easy replacement of the paper roll.

Paper from the roll is fed upwards into the printer head via a rubber roller which ensures correct alignment of the paper to the printer head.

The paper passes through the head and is sensitised by the head heaters to produce the correct printed characters. After printing, paper is fed out to the user through a slot in the Paper Tear Window on the Front Panel. Teeth along the lower edge of the window slot allow the paper to be torn off after printing.

Modifications to Improve Printer Reliability.

The Paper Tear Window has been modified to ensure paper cannot get trapped behind it. Note that the part number of this modified part is unchanged.

The new Paper Guide has been designed to ensure correct alignment of paper entering the printer head under all conditions.

The new User Instruction Label has been designed to help inexperienced operators when replacing the printer paper roll. It has pictorial instructions and the part number of the recommended paper to be used. It is fitted in a prominent position to be visible whenever the paper compartment cover is removed for paper changing.

Fitting the New Paper Tear Window

1. Switch off the 37714A and disconnect the power cord.
2. Remove the rear panel feet.
3. If Optical Modules are fitted (option UH1 or UH2), unscrew the optical shields from the input and output connectors.
4. Withdraw the outer cabinet sleeve back and out of the instrument.

5. Remove the two screws securing the Front Panel to each side of the instrument chassis.
6. The Front Panel can now be pulled forward out of the instrument after unplugging the ribbon cable to the Motherboard at socket A2 J1 (see Figure 2).
7. Remove the Paper Compartment Cover (E) by pushing down on it from above then pulling it forward and away from the front panel. The paper roll (A) will leave the instrument on spindle (F) along with this cover. Tear the paper to detach the roll from the printer head. The cover and paper roll can now be set aside.
8. With the front panel face down on the workbench, unplug A2 J4, then unscrew the five posidriv screws which secure A1 to the front panel. Lift this board assembly away from the front panel complete with the printer mechanism (see Figure 2).
9. Remove any paper still present in the printer mechanism by slowly and carefully pulling it forward and out of the printer mechanism.
10. Press the existing Paper Tear Window from the front until it detaches from the Front Panel. Discard this part.
11. Cut two 60mm strips from the new roll of adhesive tape and stick these to the inside of the Front Panel where the Paper Tear Window attaches to it.

NOTE

Remove all traces of old adhesive or adhesive tape from the Front Panel using an alcohol solution before attempting to stick the new adhesive tape to it.

12. Remove the backing from the adhesive tape, then attach the new Paper Tear Window to the Front Panel, pressing down very firmly on it's edges to obtain maximum adhesion.

NOTE

The new Paper Tear Window must be fitted with the slot teeth pointing downwards

See the close-up in Figure 1.

Fitting the New Paper Guide

1. With the A1 board Assembly on the bench, undo the two screws which secure the metal Printer Compartment Case (C) to it. Discard these screws.
2. Fit the new Paper Guide on top of the metal case (C), ensuring that it slopes towards the printer head.
3. Align it with the holes in the metal case (C), then fit the two new longer screws (torx head) and secure the Paper Guide and metal case to the A1 Assembly with the original retaining nuts. Do not tighten the nuts at this stage.

NOTE

Ensure the new Paper Guide is clear of the small capacitor on the A1 Board. There is an indent in the new Paper Guide to facilitate this.

4. Replace the A1 board assembly to the front panel and secure with the five screws.

5. Looking into the Paper Compartment from the Front Panel, ensure the metal case (C) is aligned with the left edge of the square cutout on the front panel. Slide it from left to right to achieve correct alignment, then tighten the two securing nuts.
6. Replace A2 J4 and A2 J1, then fit the front panel back into the instrument and secure with the two screws at each side of the chassis.

Fitting the User-instruction Label

1. Remove the paper roll from the spindle (F).
2. Remove the backing from the new self-adhesive User-instruction Label.
3. Align the label centrally to the inside of the Paper Compartment Cover (E) then press down firmly to achieve maximum adhesion.
4. Carry out steps 5 to 10 in the procedure Replacing the Printer Paper Roll below.
5. Replace the outer cabinet sleeve, rear panel feet and optical module shields as a reversal of the removal procedure.

The modification is now complete.

Replacing the Printer Paper Roll

This is a stand-alone procedure which should be used every time it is required to change the printer paper roll.

1. Remove the Paper Compartment Cover (E) by pushing down on it from above then pulling it forward and away from the front panel. The paper roll (A) will leave the instrument on spindle (F) along with this cover. If any paper is left on the roll, tear it across as it enters the printer head. The cover and paper roll can now be set aside.
2. If any paper is still present in the printer mechanism, it may be removed by slowly and carefully pulling the paper out of the printer mechanism.

Caution

Never press PRINT NOW or PAPER FEED keys while you are pulling the paper through the printer mechanism, as this may cause the printer head to jam.

4. Discard the old paper roll.
5. Undo the new roll of paper and using sharp scissors, cut the first four inches of the paper as shown in Figure 1 and on the new User Instruction label (see modification procedure above).
6. Place the roll of paper in compartment (C) such that the paper feeds upwards into the printer head (see Figure 1).
7. Carefully hand-feed the paper into the slot between the printer and the printed circuit board. This slot is visible looking up into compartment (C) and will be seen just behind the cylindrical printer motor.
8. By sliding the paper carefully from side to side, you will be able to push it all the way through the printer mechanism until it emerges through the slot in the Paper Tear Window (D).

Caution

Never press PRINT NOW or PAPER FEED keys while you are feeding the paper through the printer mechanism, as this will jam the mechanism.

9. Continue feeding paper until the full width has emerged through the slot, checking to ensure it emerges squarely through the window (i.e not at an angle to the front panel).

Caution

It is most important the paper is feeding squarely through the printer, otherwise it may jam the mechanism.

10. When sufficient paper has emerged, fit the paper roll onto spindle (F), then fit plastic cover with paper roll into compartment (C) taking care to wind any excess paper back onto the roll.

The plastic cover (E) is spring loaded, so must be pushed down then "clicked" into position on the front panel.

Testing

1. Switch on the instrument and check for a sensible display.
2. Obtain a pass on all instrument Selftests - a test of the printer is included in "All tests".

The instrument is now ready for use.

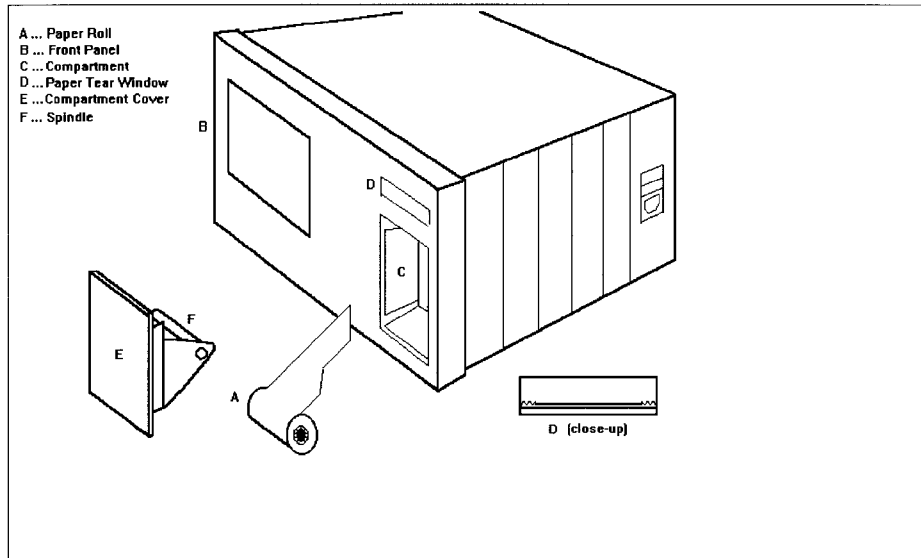

Figure 1 Location of Printer Components

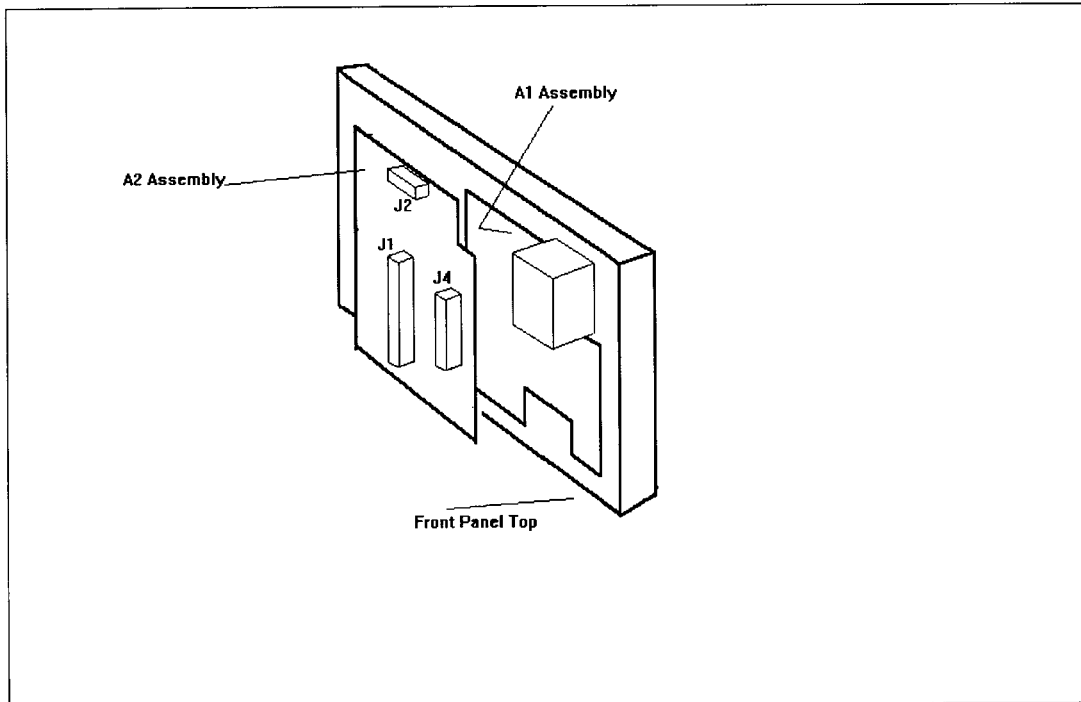

Figure 2 Location of Front Panel Board Assemblies